

PeriOptix

solutions in magnification
and portable LED illumination

Instructions, warranty and cleaning for
PeriOptix loupe optics and Hogies™ frame.

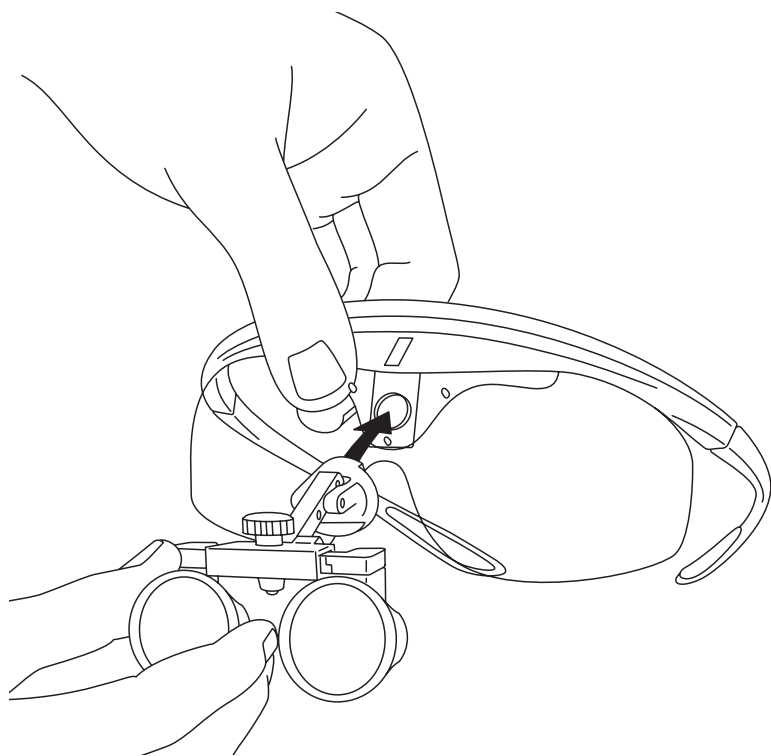

Thank you for purchasing your loupe system from PeriOptix. To ensure the optimal performance of your optics, please follow the set up directions below.

1. Contents

Inspect contents. If any item is missing, contact PeriOptix customer support.

- A. Loupe Frame
- B. Loupe Optics and Magnetic Hinge
- C. Safety Shield
- D. Magnetic Safety Shield
- E. Nose pad
- F. Headstrap
- G. Phillips Screwdriver
- H. Microfiber Cleaning Cloth
- I. Flip Paddle
- J. Lens Covers
- K. Carrying Case
- L. Allen Wrench

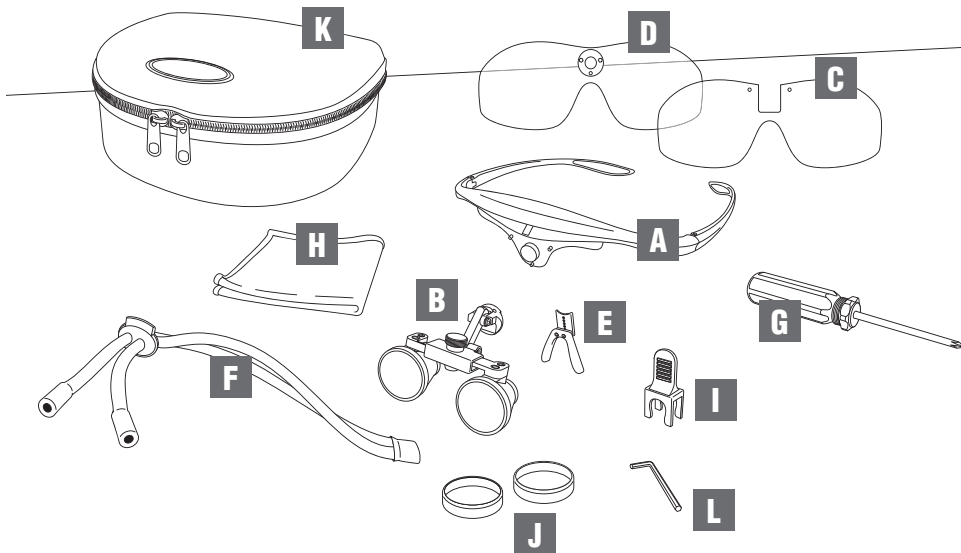

2. Loupe Glossary

- A. Frame Temple
- B. Frame Magnet
- C. Loupe Hinge With Upper and Lower Pivot Joints
- D. Hinge Set Screws on Magnetic Hinge
- E. Interpupillary Adjustment Knob
- F. Convergence Adjustment Screws
- G. Ocular Lens
- H. Objective Lens

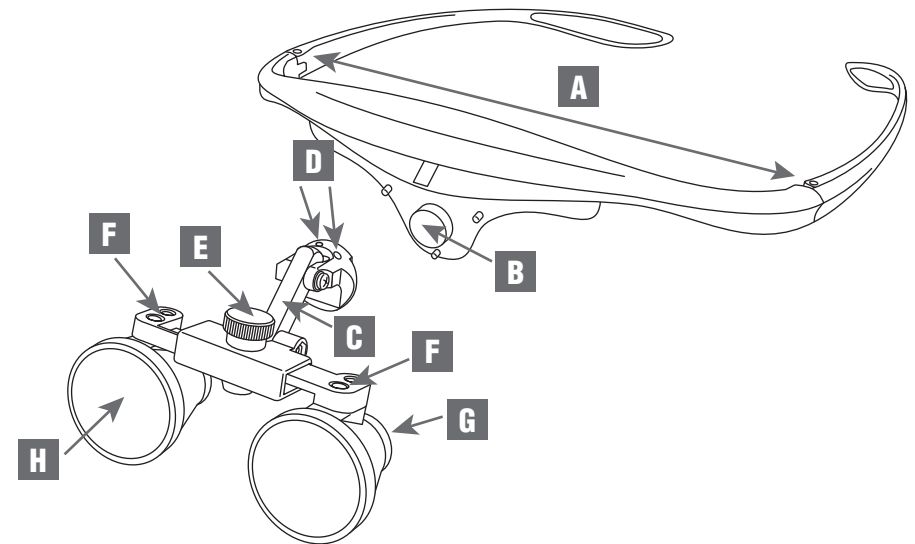

3. Loupe Adjustments

- A. Declination angle
- B. Convergence angle
- C. Interpupillary Distance
(distance between the pupils)

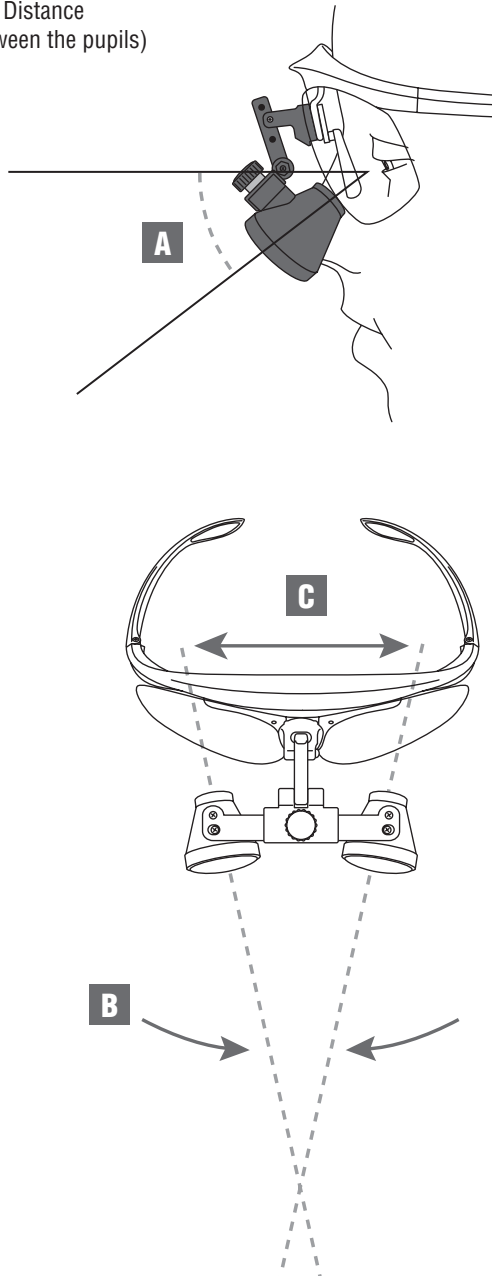

4. Disassembly

Your Hogies loupe system comes assembled with the magnetic hinge securely attached to the magnet by two set screws. To remove the loupe optics from the magnet, first loosen the set screw(s) closest to the frame. (Do not loosen the set screw further from the frame. Refer to illustrations 5.2a and 5.2b). These are located at the 10 and 2 O' Clock position on the magnetic hinge.

5. Assembly

5.0 Place safety shield on loupe frame by aligning two pilot holes with pins on frame. Shield should snap over pin. Note: shield will not remain in place without magnetic hinge. Hold in place with thumb and forefinger while attaching loupe optics.

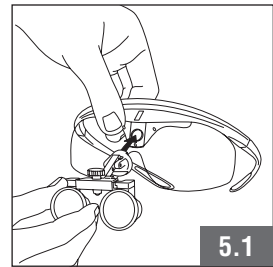
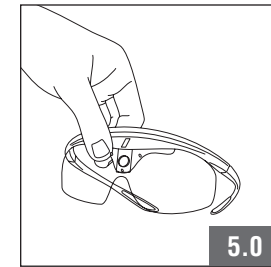

5.1 Attach magnetic hinge. Be sure shield and hinge seat completely onto the frame.

5.2a The loupe optics should be securely locked to the frame with the supplied allen wrench.

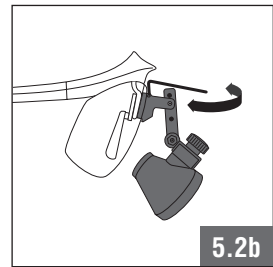
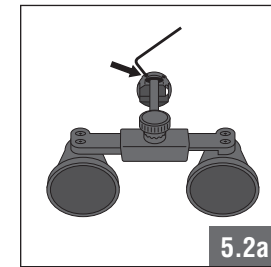

5.2b Once the loupe optics are attached, use the short leg of the allen wrench to tighten the set screw(s) on the hinge closest to the frame. Tighten the set screw until initial resistance is felt and then tighten for another 1/3 of a turn.

5. Assembly (continued)

5.3 Attach nosepiece ensuring the center pin engages center hole of nosepiece.

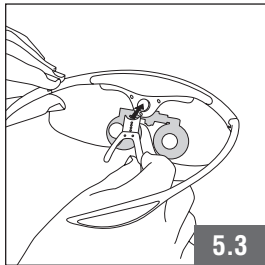

5.4 If the optional prescription insert is used, attach it to the frame, ensuring the positioning hole securely engages the pin below the frame magnet.

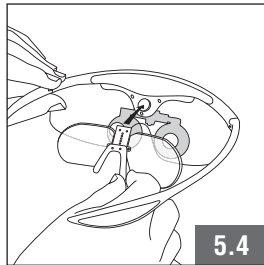

5.5 If a headstrap is desired, attach it to loupe frame temples. Note: the headstrap is recommended.

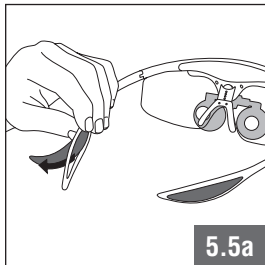

5.5a First, remove rubber inserts.

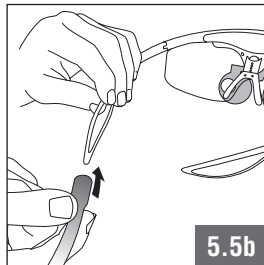

5.5b Second, squeeze together each side of loupe frame and slip headstrap ends over end of each side of frame.

5.6 To use Hogies as a safety frame, attach the magnetic safety shield.

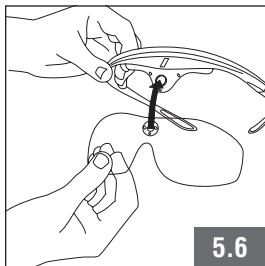

6. Properly Wearing Loupes

6.0 The loupe optics should be worn as close as possible to your eyes to achieve the greatest field of view and declination angle. When adjusting, the ocular lens should be against or close to the eyeshield with the loupes between a 45° and 60° angle.

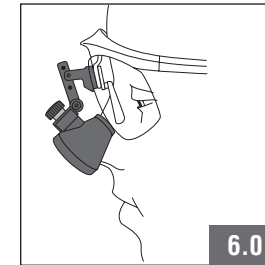

Correct loupe position.

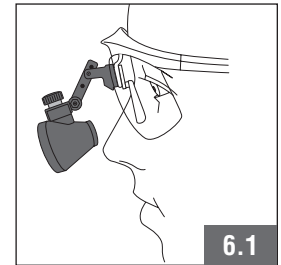

Incorrect loupe position.

6.1 Incorrect loupe position decreases field of view and declination angle.

7. Adjusting Declination Angle

7.0 To increase the declination angle of your loupes, lower the upper pivot point on the straight link. To do so, remove the screw from the middle pivot point with the Phillips screwdriver.

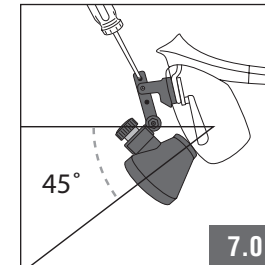

7.1 Reset the pivot point to the upper hole on the straight link and tighten screw with the Phillips screwdriver.

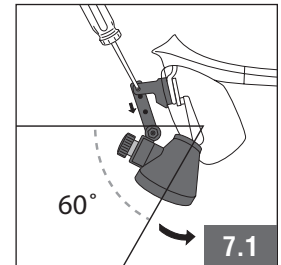

8. Securing Declination Angle

Securing the declination angle will allow you to flip-up your loupe optics so that they pivot only on the upper joint.

8.0 To do so, securely tighten the lower hinge joint with a Phillips screwdriver. Increase or decrease the tension by tightening or loosening the upper screw.

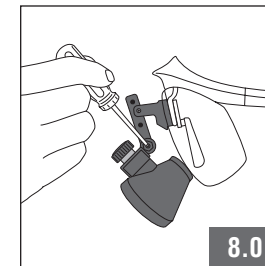

8.1 Declination angle will be secured when optics are flipped up.

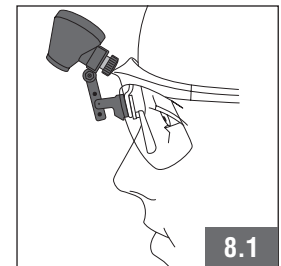

9. Focusing

9.0 Loupe optics have a preset focal distance. An easy way to determine the working distance of your loupe optics is to view your thumbs while moving them in and out of focus.

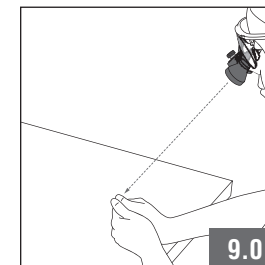

Determine focal distance.

10. Adjusting IPD

10.0 With the PeriOptix “Set and Forget” feature, the only adjustment that is usually needed is to set the IPD (Interpupillary Distance). While focusing on an object, pull up on the Interpupillary Adjustment Knob and rotate, moving the optics apart and together. You should look at the outside rings of the field of view when you are adjusting the IPD.

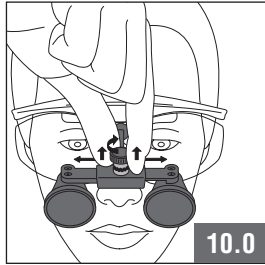

10.0

10.1 Focus on an object with the optics far apart.

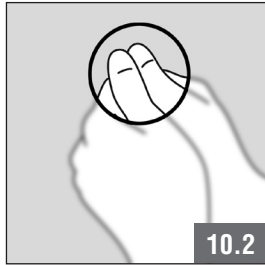

10.2

10.2 Bring the optics together until you see a single circle. Once you see a single circle, your IPD is set.

After IPD is adjusted.

11. Convergence Angle Test

The convergence angle of your loupe optics is preset according to your working distance.

11.0 To test the convergence angle, draw a single dot on a piece of paper. Focus on the dot with your loupe optics at the proper working distance. Unless you are seeing two dots, your convergence settings should not require adjustment.

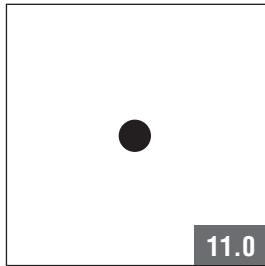

11.0

Normal.

11.1 Two horizontal dots indicate horizontal misalignment. Proceed to step 12 to correct the convergence angle.



11.1

Horizontal misalignment.

11.2 In the rare case that two vertical dots indicate a vertical misalignment, your loupes may need to be returned to PeriOptix for adjustment. Call customer service at 1-888-360-0033 to arrange for a return authorization number.

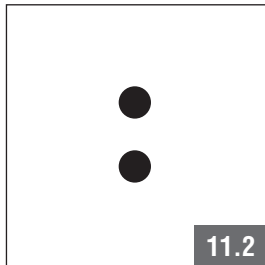

11.2

Vertical misalignment.

12. Adjusting Convergence Angle

Before adjusting the convergence angle, set the IPD (see step 10). Then, follow the instructions in step 11.0. If you still see two horizontal dots, your optics have convergence error and you need to rotate the lens barrels to eliminate the horizontal convergence error.

12.0 To adjust the horizontal convergence angle, first look downward at the loupe optics from the top to see if the barrels are equally angled.

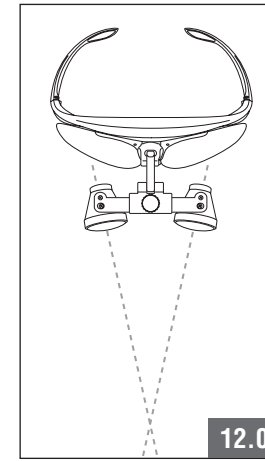

12.0

Barrels in alignment.

12.1 Barrels out of alignment will appear asymmetrical.

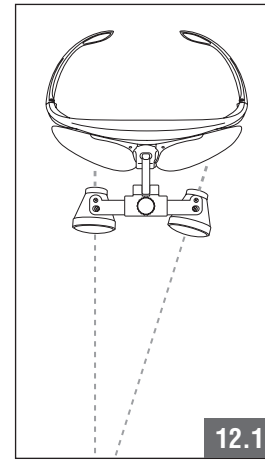

12.1

Barrels out of alignment.

12.2 If a barrel seems out of alignment, loosen both convergence adjustment screws with a Phillips screwdriver.

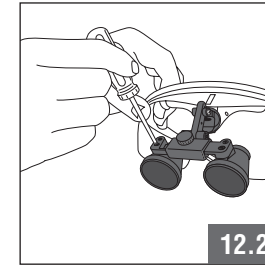

12.2

12.3 Adjust one or both barrels so they are pointing slightly and equally inward (this will give you a rough alignment).

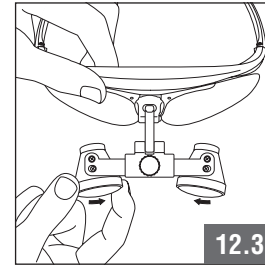

12.3

12.4 Slightly tighten both screws to keep them in alignment. Focus on the dot from Step 11. If you still see two dots, repeat steps 10.0 - 12.4 until you see one dot and both barrels are pointing inward equally. Once set, tighten both convergence screws on each barrel.

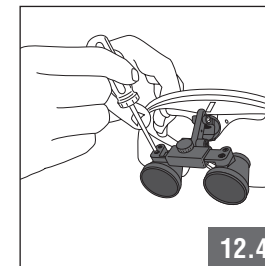

12.4

13. Warranty

Prior to returning product to PeriOptix for any reason, please call 1-888-360-0033 to request a Return Authorization (RA) number.

PeriOptix, Inc. warrants its products to be free of original defects in material and workmanship and to perform in accordance with specifications for the following terms:

Limited Lifetime Warranty:

All working parts of the loupe hinge mechanism and light attachment mechanism.

Three-Year Limited Warranty:

Optics, frames and nosepieces.

One Year Limited Warranty:

LED lamp head, cables, headband, chargers and battery packs.

Limitations of Warranty:

- Breakage or failure due to tampering, misuse, neglect, accidents, modification or shipping
- If the instrument is not used in accordance with manufacturer's recommendations or instructions
- If repaired or serviced by other than PeriOptix or a PeriOptix authorized representative

PeriOptix offers complimentary replacement side shields, headstraps and flip paddles for the life of their loupes.

Prompt inspection and reporting of missing or damaged product should be reported to shipping carrier and PeriOptix with 3 days of receipt.

If PeriOptix products or any component thereof is found to be defective or at variance with the manufacturer's specifications during the warranty period, PeriOptix will repair or replace the instrument or component(s) at no cost to the purchaser. This warranty only applies to products purchased new from PeriOptix or its authorized distributors or representatives.

The purchaser must return the product directly to PeriOptix or an authorized distributor or representative and bear the costs of shipping.

14. Cleaning and Disinfecting Lenses and Shields

Use the supplied cloth to clean the optical lenses and shields. A **lightly** moistened cloth with alcohol or eyeglass lens cleaner can also be used. **DO NOT WET OR IMMERSE THE OPTICAL LENSES IN WATER OR LIQUID.** For all other components such as the frames, nosepad and hinges, clean with an alcohol or disinfectant wipe. It is recommended that lens covers are used on the front of the loupes. These can then be removed, cleaned thoroughly, dried, and then replaced on the loupes.

15. Contact Information

Address:

1201 Puerta del Sol, Suite 305
San Clemente, CA 92673

Telephone:

888.360.0033
1.949.366.3333 (outside the US)

Fax:

949.366.0033

www.perioptix.com

PeriOptix

www.perioptix.com